

GREENLAWNS HIGH SCHOOL  
 TERMINAL EXAMINATION YEAR 2019 - 2020

SUBJECT : TECHNICAL DRAWING APPLICATIONS  
 TIME : 3 HOURS

CLASS : IX  
 MARKS : 100

Instructions:

- You must attempt three questions from Section A and two questions from Section B.
- Each Section must be answered on separate sheet.
- All construction lines must be shown.
- All dimensions are in mm.
- The intended marks for questions are given in brackets.

SECTION A (48 Marks)

(Attempt any 3)

Q.1 Refer Figure (1). Copy the given figure . Insert any six dimensions. (1)

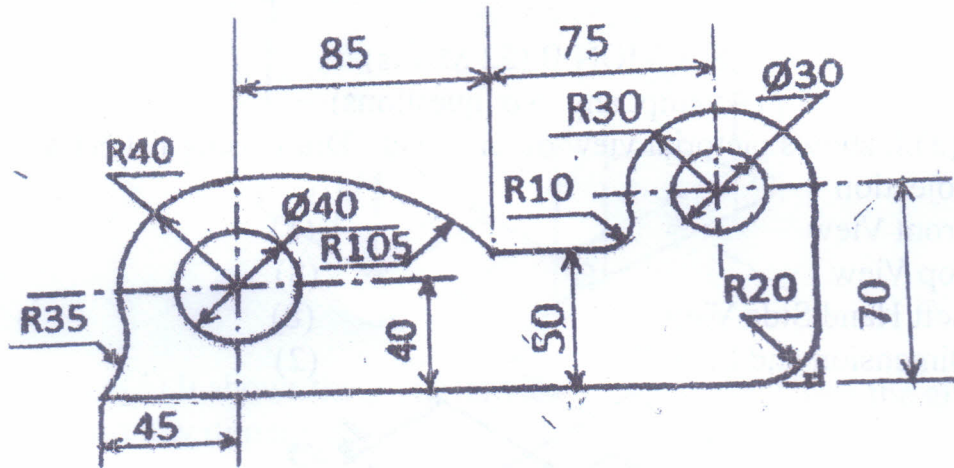

FIGURE[1]

Q.2a) Refer Figure (2). ABCDE is a regular pentagon. Line CP is parallel to line ER draw a continuous arc passing through points A,B,C,P and R as shown in the figure. (Use any method for drawing pentagon). Side of pentagon = 55mm, DR = 120mm, Angle QPR = 60°.

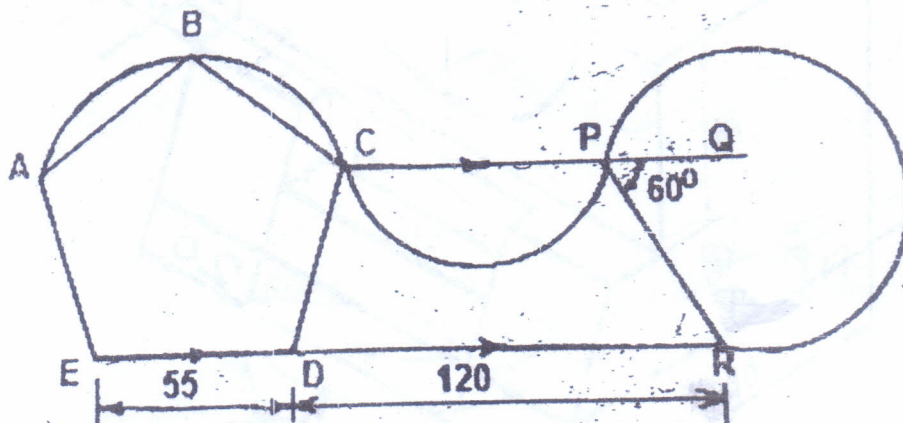

FIGURE[2]

b) Inscribe an octagon inside a square of side 100mm. Measure the side of the octagon. (4)

Q.3a) Draw Internal tangents to two circles of radii 38mm each and distance between centers 150mm. Measure and record their length. (8)

b) Construct an angle of 30°. Draw a circle of radius 35mm touching both the arms of the angle. Draw a circle of smaller radius touching both the arms of the angle and the circle of radii 35mm. (8)

Q.4a) Draw a hexagon of side 65mm. Inscribe three circles inside the hexagon such that each circle touches one side of the hexagon and two other circles. (10)

b) Construct a pentagon inside a circle of radii 50mm. Measure the side of the pentagon. (6)

Q.5a) Draw a circle of radius 65mm. Inscribe five circles inside the circle such that each circle touches the circle of radius 65mm and two other circles. (12)

b) Find the circumference of a circle of radius 28mm. (4)

SECTION B (52 Marks)  
(Attempt any two questions)

Q.6 Refer Figure(3). It shows pictorial view of an object. Draw using FIRST angle method of projection (26)

- i) Front View (8)
- ii) Top View (8)
- iii) Left Hand Side View (8)
- iv) Dimension and Labelling (2)

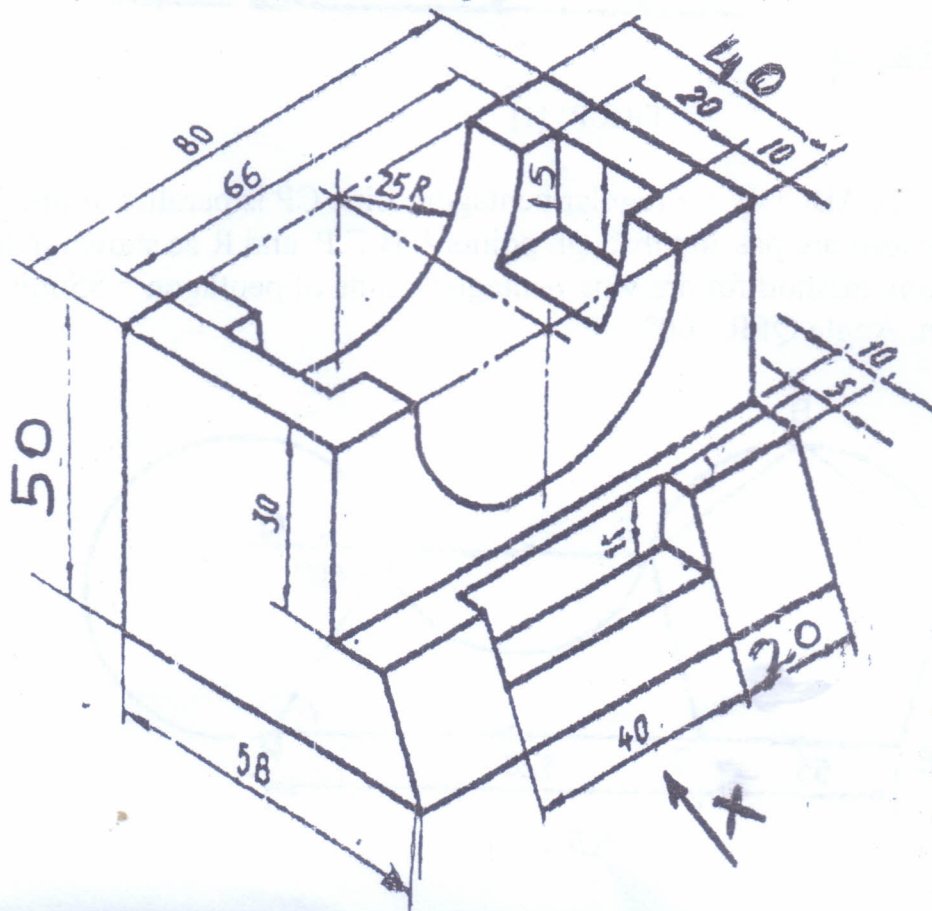

p.t.o



Q.7 Refer Figure (4). It shows pictorial view of an object . Draw using THIRD angle method of projection (26)

- i) Front View (8)
- ii) Top View (8)
- iii) Left Hand Side View (8)
- iv) Dimension and Labelling (2)

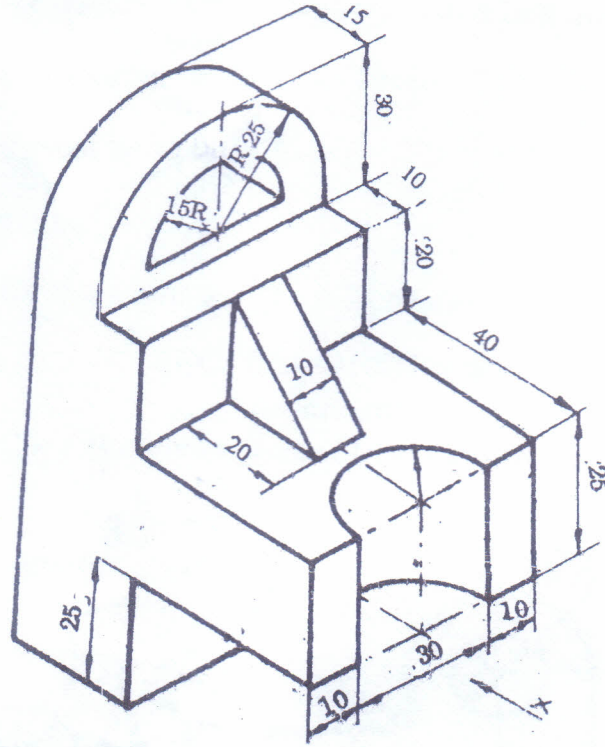
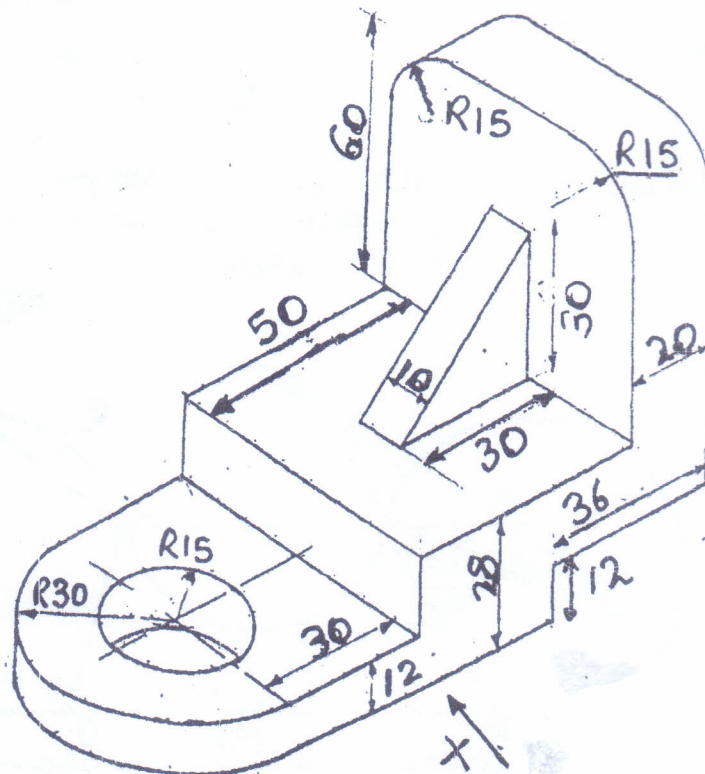

Figure [4]

Q.8 Refer Figure (5).It shows the pictorial view of an object. Copy the given figure. (Do not insert any dimensions). (26)



FIGURE[5]